

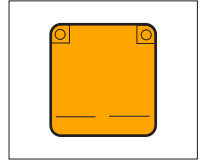

**INFORMATION FOR FIRST AND SECOND RESPONDERS**  
**EMERGENCY RESPONSE GUIDE**



**NIO ET5T**  
**ELECTRIC**





Do not dispose of vehicle keys in household trash.  
They contain materials that can be recycled.



Take the used battery to a recycling center or to your service center.

## ONLINE USER MANUAL

This guide provides the basic operating instructions of NIO ET5T. For owners who want insights and detailed information about the features and functions of the car, an in-depth online manual is available in our official website.

## Contents

0. Rescue sheet	Page 02
1. Identification / recognition	Page 02
2. Immobilisation / stabilisation / lifting	Page 08
3. Disable direct hazards / safety regulations	Page 11
4. Access to the occupants	Page 13
5. Stored energy / liquids / gases / solids	Page 17
6. In case of fire	Page 19
7. In case of submersion	Page 20
8. Towing / transportation / storage	Page 20
9. Important additional information	Page 22
10. Explanation of pictograms used	Page 24

## 0. Rescue sheet

This Emergency Response Guide covers the NIO ET5T corresponding rescue sheet.

## 1. Identification / recognition



### **WARNING**

**Silent movement or instant restart capability exists until vehicle is fully shut down.**

### ET5T Information

Vehicle manufacturer	NIO
NIO hotline	Refer to the contact table
NIO official website	Refer to the contact table

The vehicle nameplate is located under the B-pillar on the right side.



The vehicle brand logo can be found in the following places:

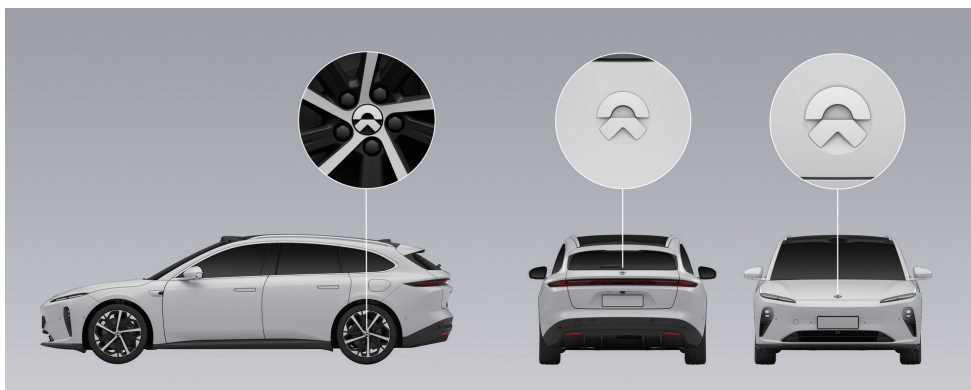

## Instrumentation and Controls

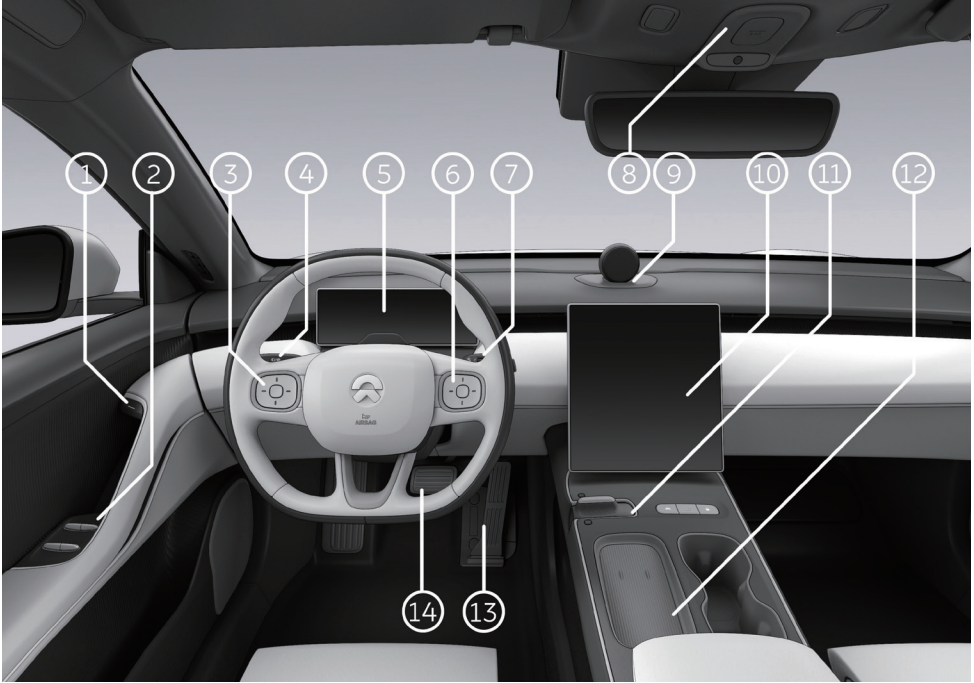







1. Electronic Switch for the Inner Door Handles
2. Window Control Panel
3. Switches on the Left Side of the Steering Wheel
4. Turn Light and Headlight Stalk
5. Instrument Cluster Display
6. Switches on the Right Side of the Steering Wheel
7. Wiper and Washer Stalk

8. Emergency Call and Reading Lights
9. Nomi Smart Assistant\*
10. Touchscreen Display
11. Gears and Central Control Panel
12. Central Control Wireless Charging Board
13. Accelerator Pedal
14. Brake Pedal

**\*Note:**  
Nomi Mate as shown in the figure

## Warning Sign Information

No.	Warning Sign Name	Warning Sign Pattern	Warning Sign Description
1	High-voltage electricity warning sign		Danger! Do not touch high-voltage components.
2	High-voltage components warning sign 1		High-voltage components. Pay attention to danger. Do not touch high-voltage components without wearing protective equipment, be careful not to get electric shock!
3	High-voltage components warning sign 2		High-voltage components. Pay attention to danger. Do not touch high-voltage components without wearing protective equipment, be careful not to get electric shock and high temperature burns!
4	High-voltage battery pack warning sign		Precautions for the use of HV battery pack.
5	High-voltage harness sign		The high-voltage components of the vehicle are connected using orange high-voltage harnesses. Do not touch high-voltage components without wearing protective equipment!
6	Mutual compatibility identifiers used for charging the car		Mutual compatibility identifiers to guide you charging the car are found in the car's charging port. When selecting the charging gun, you must make sure the identifier on the charging gun equals one of the identifiers found in the car's charging port, either C, K or L. Voltage ranges related to those identifiers are as follows: C: AC ≤ 480V K: DC 50V to 500V L: DC 200V to 920V

## Vehicle Identification Number (VIN)

The vehicle identification number (VIN) is embossed on the floor under the front passenger seat.

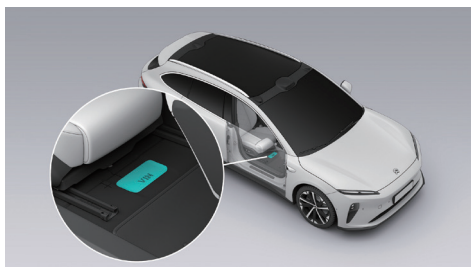

The vehicle identification number (VIN) can be found in the following places:

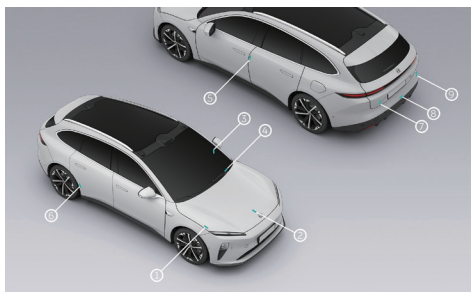

1. Inside the hood
2. Above the end of the front drive motor
3. On the left side of the instrument panel beam
4. Lower left corner of the front windshield
5. Under the B-pillar on the left side of the body
6. Under the right rear door frame
7. Above the end of the rear drive motor
8. Above the rear floor
9. On the right side of the trunklid

You can also read the vehicle identification number (VIN) with a diagnostic tool (NIO Diagnostic System Generation II (BD2)) that is compatible with the vehicle:

1. Connect the diagnostic tool to the vehicle diagnostic port, and turn on the diagnostic tool.

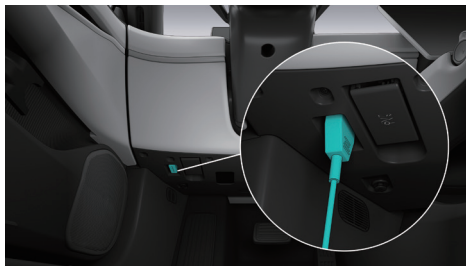

2. Start the diagnostic tool and log in to the main interface of the diagnostic tool.
3. The diagnostic tool will automatically read the vehicle identification number and display it on the current interface of the diagnostic tool.

## Microwave Window

There is a microwave window at the front windshield of the vehicle. Your toll payment device can be installed here.

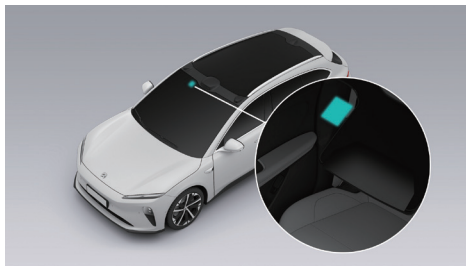



### Drive Motor Identification Mark

The front drive motor identification mark is located under the motor.

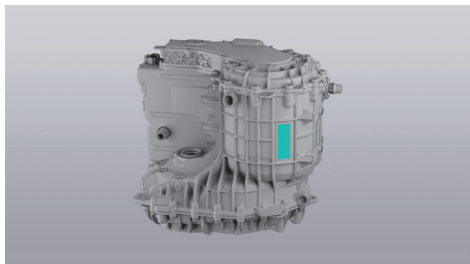

The rear drive motor identification mark is located on the lower left side of the motor.

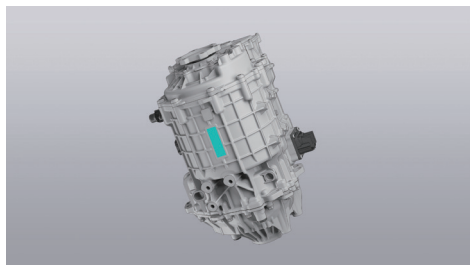

## 2. Immobilisation / stabilisation / lifting

### Set Up Warning Signs

In the event of an emergency, drive the vehicle to a safe area while ensuring safety, then step on the brake pedal to stop the vehicle; put the vehicle in Park, and turn on the hazard warning lights on the center console to alert the surroundings.



1. P gear switch
2. Hazard warning lights

Open the cover at the bottom of the rear trunk's storage space, and inside you will see the vehicle kit, take out the warning triangle and reflective vest, put on the reflective vest and place the warning triangle within 50 meters to 100 meters behind the vehicle (when it's on an expressway, place it 150 meters behind the vehicle; when it's at night, place it 100 meters further than the normal distance; in the event of rain and fog, place it 200 meters behind the vehicle).

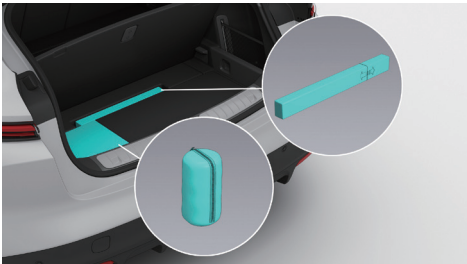

How to assemble the warning triangle:

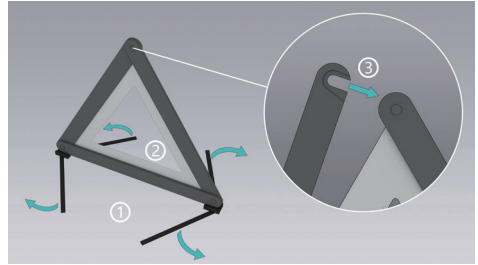

1. Unfold the bracket under the triangle.
2. Unfold the sides of the triangle.
3. Fasten the snap button on the top of the triangle.

### Call for Road Assistance

In case of accidents such as a vehicle collision, water soaking, battery pack fire, etc., call the NIO Hotline for road assistance after setting up the warning signs. Please leave the vehicle as soon as possible while ensuring the safety of the surrounding environment and maintain a safe distance of over 15 meters. And the Road Assistance team will come to help you as soon as possible.



### WARNING

**If there is a risk of battery fire, the vehicle will automatically cut off power, and warning messages will pop up on the instrument cluster and center display. Please leave the vehicle as soon as possible and call for rescue while ensuring the safety of the surrounding environment.**

If the vehicle is connected to the network, you can press the SOS button on the roof to call for road assistance (long press once, or short press twice), and you can cancel the call on the center display within 8 seconds after making the call. The backlight of the SOS button indicates the status of the SOS feature: a green light means that the SOS feature is available; a green flashing light means that road assistance is being called; a red light or a red flashing light means that the SOS feature is unavailable, in such a situation you need to contact NIO Service Center immediately.



### DESCRIPTION

If the vehicle is connected to the network and an accident occurs and the airbag is ejected, the vehicle will automatically call for rescue to protect your life.

## Tire Replacement

When the vehicle is subject to a severe air leakage and cannot continue driving, park the vehicle on a flat and solid road and put it in Park, stay away from busy and congested roads, then put on your reflective vest and place the warning triangle, turn on the hazard warning lights, then contact NIO Service Center for a tire replacement.



### WARNING

- **When replacing tires, you need to choose new tires with the same specifications as the original tires. Tires with inconsistent specifications may affect the maneuverability of your vehicle and cause your vehicle to lose control.**
- **When jacking your vehicle for tire replacement, please ensure that nobody enters the area under the jacked vehicle. Otherwise, injury may occur as a result.**
- **If anyone is in your vehicle, please do not jack your vehicle.**
- **Lift your vehicle only at the prescribed underbody jacking point.**
- **When jacking your vehicle, please do not place any objects on or under the jack.**
- **Never jack your vehicle on an uphill, downhill or sloping road.**
- **The jack is only suitable for jacking your vehicle for tire replacement.**

How to replace the tire:

1. Have a jack and a spare tire of the right specification ready for the tire replacement.

- Place a block in front of the tire diagonally to the flat tire to prevent the vehicle from sliding.
- Use the bolt cover remover in the vehicle kit to remove the bolt covers, and loosen the bolts counterclockwise with the wheel wrench.



### CAUTION

There is a special protective coating on the exterior of the rim. During the disassembly and assembly of bolts, tires or rims, the operating area of the rim shall be properly protected to prevent the surface of the rim from being accidentally scratched by hard objects.

- Place the jack below the correct jacking spot on the vehicle.

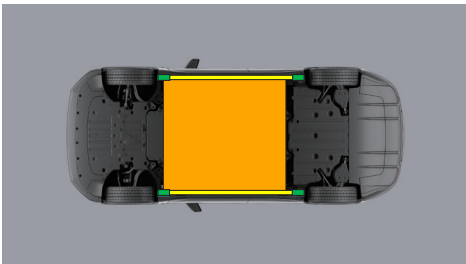

- Appropriate lifting points
- Appropriate points vehicle on side
- High voltage battery



### WARNING

**Confirm that the jack is set at the correct jacking point. Incorrect jacking points can damage the vehicle or cause it to slip off the jack and cause personal injury.**

- Jack the vehicle up to a tire replacing height. As the jack touches the vehicle and jacks it up, double check to make sure that the jack is in the correct position.

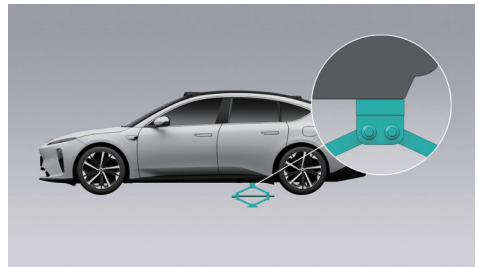

- Remove the wheel bolts and replace the tire. When installing the wheel, make sure the bolts are aligned with the mounting holes, and that the metal side of the wheel is in proper contact with the mounting surface.
- After installing the wheel bolts, lower the vehicle completely to the ground (using the jack), then use a wrench to tighten all the bolts clockwise, and then use a torque wrench to tighten the vehicle bolts to the specified torque value.
- Check the tire pressure after the tire is replaced, inflate to the specified tire pressure if necessary, then install the tire valve cap.
- Put the tools, jack, and the flat tires away in a secure manner.

### 3. Disable direct hazards / safety regulations



#### WARNING

**Be aware that not every high voltage component is labelled. Always wear the appropriate PPE (Rubber insulated gloves / insulated rubber shoes / tools with insulating protective cover / goggles). Do not attempt to open the high voltage battery.**

#### Protective Equipment for Rescue Operations

The vehicle power system is driven by a HV battery. In the event of a serious collision, the high-voltage power or battery fluid may be leaked; therefore, the rescue operation to the vehicle should be undertaken by professional rescuers who wear corresponding protective devices to secure personal safety.



#### WARNING

**To avoid electric shock injury, please make sure that, when operating the vehicle, you do not carry any metal object (such as necklace, watch, etc.).**

#### Electrical protection

Please wear the following protective devices to avoid injury from high-voltage electric shock:

- Insulated rubber gloves (be able to insulate against voltage above 500V)
- Goggles
- Insulated rubber boots
- Tools with insulated protective cover

#### Chemical protection

In the event of a battery leakage or potential risk of battery leakage, please wear the following protective devices to prevent injury to your skin and face:

- Face shield
- Solvent resistant gloves

#### Cut off the High-voltage Circuit

To cut off the high-voltage circuit, first disconnect the emergency HV cut-off plug (located in the left area of the front trunk), and then disconnect the 12 V battery negative terminal (located in the front trunk near the front windshield).



How to cut off the high-voltage circuit:

1. Pull the hood handle cover plate in the passenger compartment twice to release the hood.



2. Lift the hood.



3. Disconnect the emergency high-voltage cut-off plug, then cut off the high-voltage supply circuit, remove the plug and keep it in a safe place.

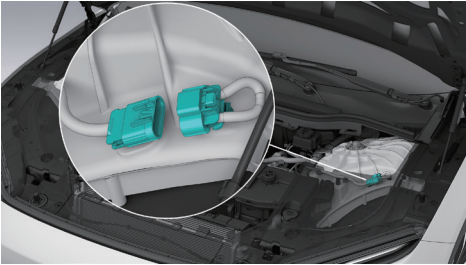
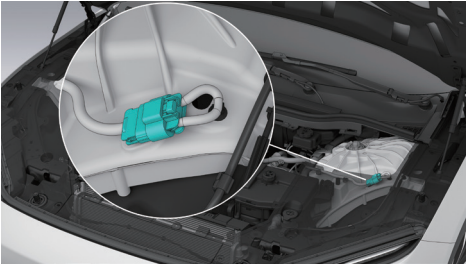

4. Disconnect the cable from the 12 V battery negative terminal, and wrap it with a protective layer after disconnection to prevent conduction due to accidental contact from occurring.

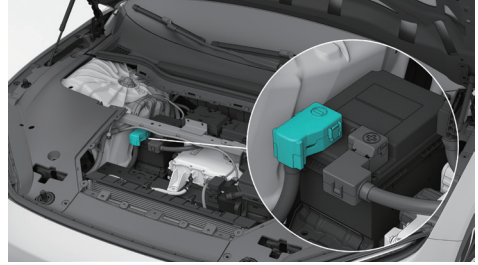

### Airbag

The vehicle airbag system includes frontal airbags and side airbags. The frontal airbags include front row head airbags, of which the driver airbag is located inside the trim cover of the steering wheel, and the front passenger airbag is located inside the instrument panel; the side airbags include front row side airbags (located on the outer side of the front seats, and the inner side of the driver's seat), and curtain airbags (located above the doors on both sides, in the ceiling area from the A-pillar to the C-pillar, where there are curtain airbag gas cylinders inside). The word "AIRBAG" is marked on the places where the airbag is placed to remind you that there is an airbag herein.

## 4. Access to the occupants



### Driver's Seat Adjustment

#### To adjust the seat position via a button

You can adjust the position of the driver's seat through the buttons below the seat.



#### 1. Seat cushion length adjustment

Toggle the button back and forth to adjust the length of the cushion.

#### 2. Seat cushion front tilt angle adjustment

Rotate this button to adjust the front tilt angle of the seat cushion.

#### 3. Seat forward/backward adjustment

Toggle this button back and forth to move the seat forward or backward.

#### Seat height adjustment

Toggle the center portion of this button up or down to raise or lower the seat.

#### 4. Backrest reclining adjustment

Toggle the upper end of this button back and forth to adjust the reclining of the seat backrest.

#### 5. Lumbar support adjustment

Press the up, down, left, or right button to adjust the lumbar support.

### Customizable Comfort Button

Press the middle button to turn on or off the comfort function. Press and hold the middle button to save the seat's current comfort options.



#### WARNING

- Before seat adjustment (forward and backward, height, backrest, etc.), make sure that there is sufficient safe space for the seat and children, occupants, and pets in the rear row to avoid squeezing or smacking into children, occupants, and pets in the rear row.
- Adjust the driver's seat position and headrest when the vehicle is in PARK. Seat position and other adjustments while driving may cause safety risks.
- During seat adjustment (forward and backward, height, backrest, etc.), avoid putting your hands or other parts of the body on the seat movement path to prevent pinching and colliding.
- Ensure that the seat is locked after position adjustment.

### Controlling the movement of the driver's seat on the center display

You can control the movement of the driver's seat on the center display.



## Opening the Hood with Power

### Trunklid

#### Opening and Closing the Trunklid by Pressing the Button

When you carry the smart key, lightly press the pressure plate on the handle of the trunklid to open the trunklid.

Your vehicle is equipped with a one-button trunklid closing feature.

Press the button on the trunklid to automatically close and lock the trunklid, and you will hear a “click” to confirm the closure.

#### Opening and Closing the Trunklid with the Center Display

Swipe right on the left edge of the center display to enter the Quick Settings page, then touch Rear Trunk to open the rear trunk.

#### Opening and Closing the Trunklid with the Smart Key

Opening the trunklid: press and hold the trunklid button on the smart key, and the trunklid will open automatically.

Closing the trunklid: press and hold the trunklid button on the smart key, and the trunklid will close automatically.

### Door Handle

When the vehicle is fully unlocked, the outer door handles will pop up automatically, and you can open the door via sensing by gently touching the inside of the door handle.

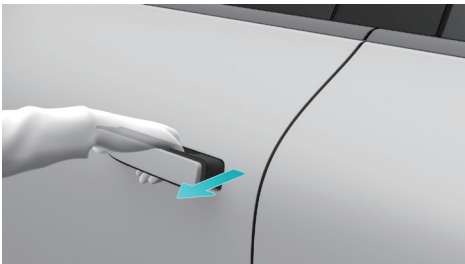

You can open the door from inside by pressing the electronic switch on the corresponding inner door handles. Press once if the door is unlocked, or press twice if the door is locked, then the corresponding door will pop open.



### Emergency Unlocking from the Outside

When the vehicle cannot be unlocked from the outside by regular methods (smart key, keyless unlock, mobile app or NFC), you can use the physical emergency key to unlock the driver's door.

#### CAUTION

Please take the physical emergency key out of the vehicle and retain it for use in emergencies.

How to use the physical emergency key:

1. Toggle the slider on the physical emergency key, and pull out the metal key part of the emergency key.

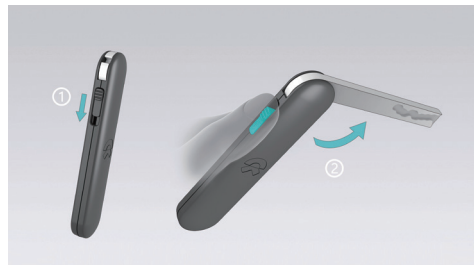

2. Press and hold the front part of the outer door handle of the driver's door to unfold the outer door handle.



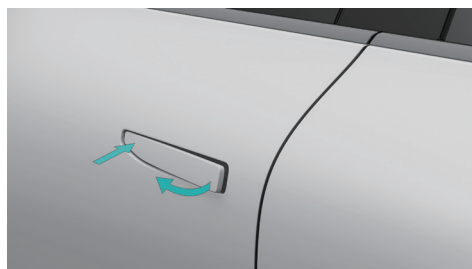

3. Hold the unfolded outer door handle with one hand while inserting the physical emergency key into the keyhole in the outer door handle with the other hand, and turn the key counterclockwise to unlock the driver's door.



4. When locking, press and hold the front part of the outer door handle, turn the physical emergency key counterclockwise for one unlocking action, and then turn the key clockwise to lock the driver's door.

### CAUTION

After having unlocked the driver's door using the physical emergency key, if you want to use the smart key to lock the door, you need to first open and close the driver's door once to reset the door lock cylinder, so as to prevent the driver's door from being unlocked and to keep the vehicle secure.

### Open the Door from the Inside in an Emergency

When the whole vehicle is locked, if you need to open the door in an emergency (such as when the door handle electronic switch fails, or the vehicle is soaked in water), pull the mechanical switch off the inner door handle once to open the corresponding side door.



### CAUTION

- When the 12V battery of the vehicle is low on power, the physical emergency key can only be used to unlock the door on the driver side. At such moments it cannot be used to unlock the whole vehicle. The other doors can only be unlocked and opened by pulling the mechanical switch for the inner door handle.
- The windows may not be able to perform lowering operation when the door is opened using the mechanical switch for the inner door handle because doing so would risk damaging the window trim panel.
- Neither rear door can be opened from inside when the child-protection lock function is enabled. They can only be opened from outside once the whole vehicle is unlocked.
- In the event of an accident that is of sufficient gravity to trigger airbag deployment, the child-protection lock on the rear door will be unlocked automatically.

### Emergency Opening of Trunklid

Open the square block above the latch from the inside of the rear trunk, and then use your fingers to press and hold the white button to open the trunklid.

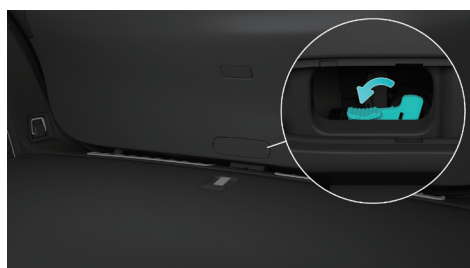

## Windows



1. Laminated glass
2. Tempered glass

## Vehicle Cutting Area









### **WARNING**

**Professional rescue personnel must use suitable tools such as hydraulic knives when cutting vehicles, and wear appropriate personal protective equipment to avoid serious personal injury.**

If cutting is required during rescue, appropriate tools should be used. The high-voltage and high-pressure areas of the vehicle shall not be cut, such as airbag-related components, high-voltage components, etc.

## 5. Stored energy / liquids / gases / solids

	  	12V
	     	350V

### E-Powertrain System Information

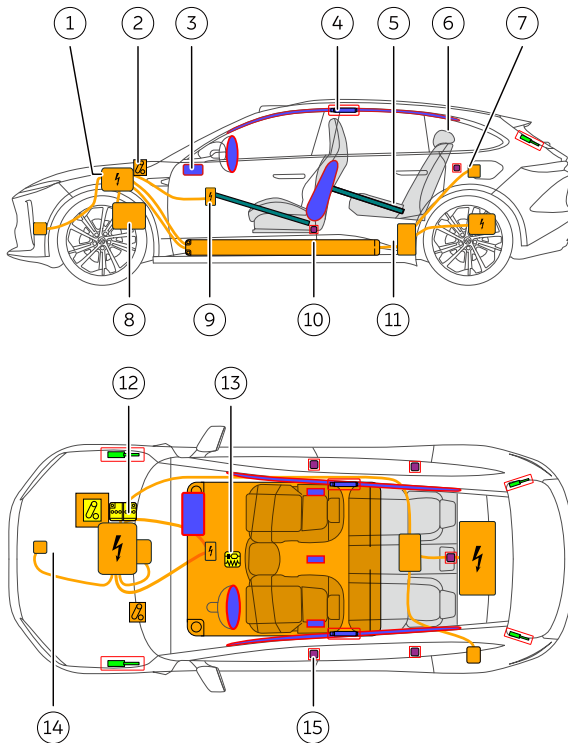

1. High voltage DC converter integrated component
2. Emergency HV cut-off plug
3. Airbag
4. Curtain airbag gas cylinder
5. Structural reinforcement
6. Curtain airbag
7. Charge port

8. Drive Motor
9. Air conditioning HV electric heater
10. High voltage battery
11. Rear HV power distribution unit
12. 12 V battery
13. Airbag control unit
14. Air conditioning compressor
15. Seat belt pre-tensioner



## High Voltage Battery

The vehicle is equipped with a lithium-ion high voltage battery. Be careful not to damage the high voltage battery when lifting the vehicle from below. Take extra care not to break the battery's bottom plate when using rescue tools.



### WARNING

- **Before repairing, removing, and installing high-voltage components, it is necessary to turn off the power supply and confirm that the emergency power switch and 12V power supply have been disconnected. After turning off the power, let the vehicle sit for more than 5 minutes.**
- **Personnel without corresponding qualifications are prohibited from operating high-voltage components; operators must take insulation protective measures such as wearing insulated gloves that meet the requirements and must not carry any metal items.**

## Drive Motor

The electric drive system is responsible for the power output of the vehicle, which can convert the DC energy of the high voltage battery pack into mechanical torque in a controllable way, and transmit it to the wheels to drive the vehicle. In addition, in the braking state, the electric drive system can also regenerate braking energy to charge the high voltage battery pack, and realize functions such as reversing. The vehicle is equipped with two electric drive systems, of which the front electric drive system is installed on the front sub-frame, and the rear electric drive system is installed on the rear sub-frame.



## 12 V Battery

The 12 V battery powers the SRS, windows, locks, touchscreens, vehicle lighting, etc.

## Rescuing the Vehicle with Battery Leakage



### WARNING

**In case the vehicle falls into a collision accident and causes fluid leakage of the high-voltage battery, it should be handled by professional rescue personnel, who must wear protective mask and solvent isolation gloves, and must not touch the liquid directly.**

The leakage of HV battery may cause a high temperature or even a fire; therefore, please cool down the HV battery before dealing with the leaked liquid:

- In the event of a small amount of leakage, use an absorbent pad to adsorb the liquid and place it in a closed container, or dispose of it by incineration.
- In the event of a large amount of leakage, treat the liquid as a hazardous chemical, splash calcium gluconate solution to deal with it.

### CAUTION

If the human body accidentally comes into contact with the leaked liquid, do try to remove the contaminated clothing and immediately wash it with soap and plenty of water for 15 minutes, until no chemical remains. If the one does not get better or even feels unwell, he/she should seek immediate medical attention.

## 6. In case of fire



USE LARGE AMOUNTS OF WATER



BATTERY RE-IGNITION!



DO NOT SUBMERGE VEHICLE TO EXTINGUISH BATTERY

### Rescuing the Vehicle on Fire



#### WARNING

- In case the vehicle is in fire, do not directly touch any part of the vehicle. It should be operated by professional rescue personnel wearing proper protective equipment.
- The gas stored in the cylinder of side curtain and the high-pressure cylinder of air suspension may be heated to expand and explode in a high-temperature environment; therefore, please be careful before the operation to avoid personal injury.

If the vehicle catches a fire that does not touch upon the HV battery, the fire extinguisher can be used to put out the fire.

If the vehicle's HV battery catches a fire or gets heated, or is even bent, ruptured, or damaged, use a large amount of water or water mixed with foam extinguishing agent (with F500 recommended) to cool down the HV battery, and then monitor the battery for another one hour after it has cooled down completely (which may take up to 24 hours) to ensure that the battery temperature will no longer rise before storing the vehicle in an open, flat ground with a 15-meter safety zone set to prevent unauthorized personnel from approaching the vehicle.



#### WARNING

After the high-voltage battery on fire is handled with cooling measures, be aware of the risk of re-burning of the high-voltage battery to avoid danger during transportation.

## 7. In case of submersion

### Rescuing the Vehicle in Water

#### CAUTION

It is recommended not to stay in deep water (preferably not exceeding the battery base plate) for a long time when the vehicle is wading. Otherwise, it may cause damage to the high-voltage components of the vehicle.

On the premise that the vehicle body and chassis are not damaged, there will be no greater risk of electric shock caused by its short-time immersion in water. However, when dealing with the submerged vehicle, the professional rescuers shall wear appropriate rescue protective equipment.

Under the condition of ensuring insulation protection, pull the vehicle out of the water, open the door, power off the vehicle, and then clean the water stains inside the vehicle. After checking for electricity leakage, cut off the high-voltage circuit normally.



#### WARNING

**When dealing with flooded vehicles, if rescue personnel do not wear appropriate protective rescue equipment, serious injury or even death can occur as a result.**

## 8. Towing / transportation / storage

**STORE AT SAFE DISTANCE FROM OTHER VEHICLES!**



**BATTERY RE-IGNITION!**



### Towing a Vehicle that Had an Accident

#### CAUTION

- This vehicle is not suitable for traction with wheels on the ground. Do not use a traction chain to tow the vehicle directly.
- When the vehicle is on snow, mud, or sand, or when the wheels are locked and unable to rotate freely, do not use a towing hook to tow the vehicle. Please contact the NIO service center.

If you need the vehicle to be towed, please call a flatbed trailer to transport the vehicle.  
How to tow a vehicle:

1. Take out the hitch from the vehicle kit in the rear trunk.

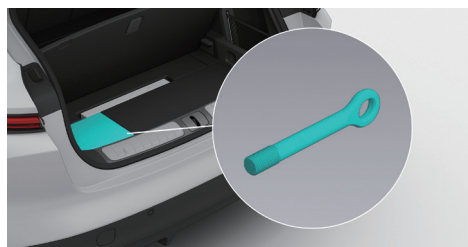
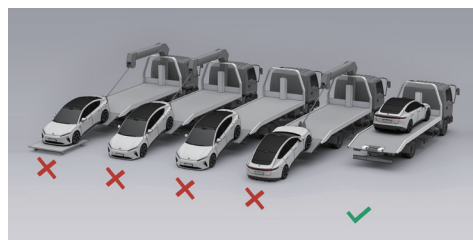

2. Press the lower end of the front towing flap of the vehicle to open it (1 in the picture), insert the hitch into the hole and rotate until the hitch is firmly seated (2 in the picture). The rear hitch (if present) is installed in the same way as the front hitch.



3. Press the brake pedal while the vehicle is in the Park gear, go to the Settings page from the control bar at the bottom of the center display, tap **Driving/Parking > Neutral Mode**, then the vehicle will be released from the parking brake and can be towed.
4. Power the vehicle off before towing, turn on the hazard warning lights, make sure that there is no one in the vehicle and lock the entire vehicle.
5. Install the tow chain on the hitch and slowly tow the vehicle onto the flatbed.
6. After the vehicle is towed to the designated location on the flatbed, use brake stops and wheel straps to fix the tires.
7. Before having the vehicle transported on a flatbed, exit Neutral Mode on the center display to prevent the vehicle from being damaged due to bumps during transportation.

## CAUTION

- Only when there is no safety risk to the vehicle can it be towed away from the site. If the vehicle battery pack is deformed, leaking liquid, or emitting smoke, safety risks shall be eliminated first.
- When it is unable to switch to the Neutral mode normally, try to re-start the 12V battery. If the parking brake cannot be released, the vehicle can be transported in as short a distance as possible by using tire slides or wheeled trailers.
- Do not depress the brake pedal or accelerator pedal hard while exiting the Neutral Mode on the center display.
- When the parking brake is released and the vehicle can be towed, there is a risk that the vehicle may slide down on a slope. If necessary, please use brake stops in conjunction with the parking brake.

## 9. Important additional information

### Must read

Thank you for choosing NIO's ET5T model (hereinafter referred to as "ET5T"). ET5T is a smart electric sedan. During your green journey with ET5T, you will get a seamless and considerate user experience.

Before starting your journey with ET5T, it is recommended that you read the User Manual from the center display to get all the information you need to use the vehicle. This Guide only covers the basic information of the vehicle, emergency response measures, and the corresponding rescue measures. For detailed information on all vehicle features, please refer to the User Manual from the center display. For information related to warranty and maintenance, please refer to the Warranty Manual from the center display.

The contents of this guide shall not be reproduced or modified in whole or in part without legal and valid authorization.

To avoid failure of the vehicle's function or personal injury, vehicle parts shall not be modified, adjusted or dismantled without legal and valid authorization.

The labels, logos and pictures used in this guide are for illustration purposes only, and the content is for reference only.

Please strictly follow the warning information in this guide to use your vehicle more safely.



## Warning Information



### **WARNING**

**This content is closely related to personal safety and must be complied. Failure to comply may lead to personal injury or serious accident.**

### **CAUTION**

This content gives you tips on how to avoid possible vehicle damage or property damage.















### **NOTE**

This content gives you suggestions for better use of your vehicle.

If you have any questions about this guide, please call the NIO hotline, or log on to the NIO official website to obtain the latest version of the ET5T User Manual.

If you need assistance in an emergency, please call the NIO hotline.

## 10. Explanation of pictograms used

	Warning high voltage		Flammable
	Caution		Hazardous to the human health
	Air-conditioning component		Acute toxicity
	Electric vehicle		Corrosives
	Bonnet		Gases under pressure
	Boot		Explosive
	Use thermal Infrared camera		Use water to extinguish the fire