

Krockkudde	Pump med lagrad gas	Förspännare till säkerhetsbälte	SRS-kontrollenhet
Låg spänning i batteri	Gasfjäderben /Förspänd fjäder	Zon med hög styrka	Zon som kräver särskild uppmärksamhet
Lufttank	Lågspänningsanordning som kopplar bort högspänning	Kabelskuren	Högspänningsbatteripaket
Högspänningsströmkabel /-komponent			

1. Identifiering / igenkänning



Tyst rörelse eller omedelbar återstartsfunktion finns tills fordonet har stängts av helt.



Modellnamn



Märkesnamn

2. Immobilisering / stabilisering / lyftning

A. IMMOBILISERA FORDONET:

- Lägg i växel P
- Aktivera varningslampan på den centrala konsolen



B. LYFTPUNKTER:

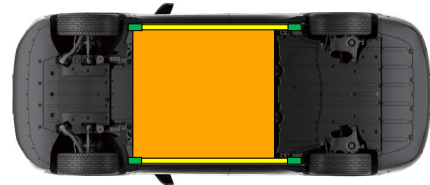

- Lämpliga lyftpunkter
- Lämpliga punkter på fordonets sida
- Högspänningsbatteri

3. Inaktivera direkta risker / säkerhetsregler



Du bör känna till att alla högspänningskomponenter inte är märkta. Använd alltid lämplig personlig skyddsutrustning (gummiisolerade handskar/skor med gummiisolerings/verktyg med isolerande skyddsbeläggning/skyddsglasögon). Försök inte öppna högspänningsbatteriet.

HUVUDSAKLIG INAKTIVERINGSMETOD

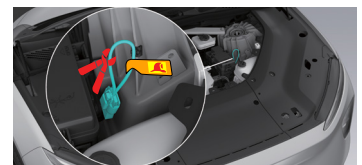
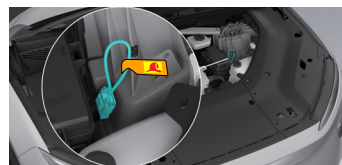

ALTERNATIV METOD

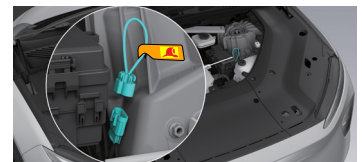
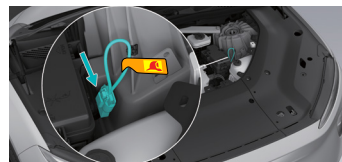
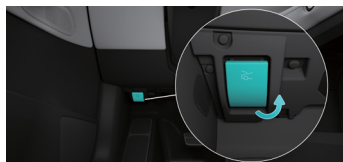
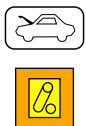

ÅTKOMST TILL BATTERI PÅ 12V

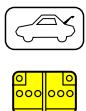



4. Åtkomst till passagerare



Justering av förarsäte (elektrisk)

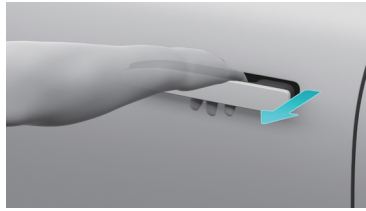

Utvändigt dörrhandtag



Justering av passagerarsäte (elektrisk)



Invändigt nöddörrhandtag



Justering av ratten



Dörregel

Glastyper:

Laminerat glas



Härdat glas

5. Lagrad energi / vätskor / gaser / fasta ämnen

		12 V
		350 V
		1000 g

6. Om det börjar brinna

ANVÄND STORA MÄNGDER VATTEN

NYTÄNDNING AV BATTERI!

SÄNK INTE NER FORDONET I VATTEN FÖR ATT SLÄCKA BATTERIET



7. Vid händelse av att vatten tränger in

Luta fordonet åt ena sidan så att vattnet rinna ut ur fordonet och högspänningsbatteriet.

Använd lämplig personlig skyddsutrustning. Avlägsna fordonet från vattnet och fortsätt med normal högspänningsfrånkoppling (se kapitel 3). Fordon som kört ner i saltvatten ska hanteras varsamt då risken för brand i högspänningsbatteriet är högre.

8. Bogsering / transport / förvaring

FÖRVARA PÅ SÄKERT AVSTÅND FRÅN ANDRA FORDON!

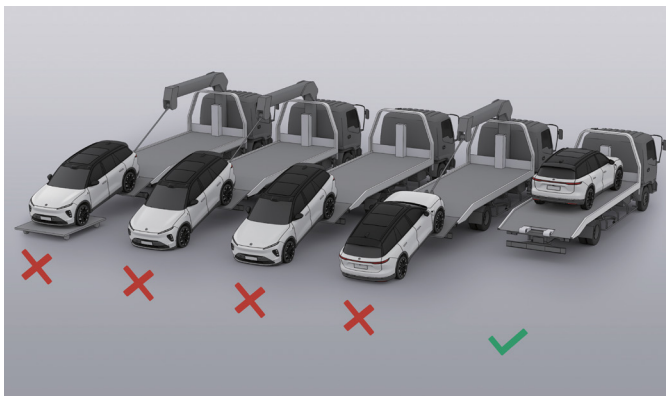

Metod för bogsering/transport



NYTÄNDNING AV BATTERI!



Krokförvaring



Krokplats

9. Viktig extrainformation

Tillverkarinformation NIO









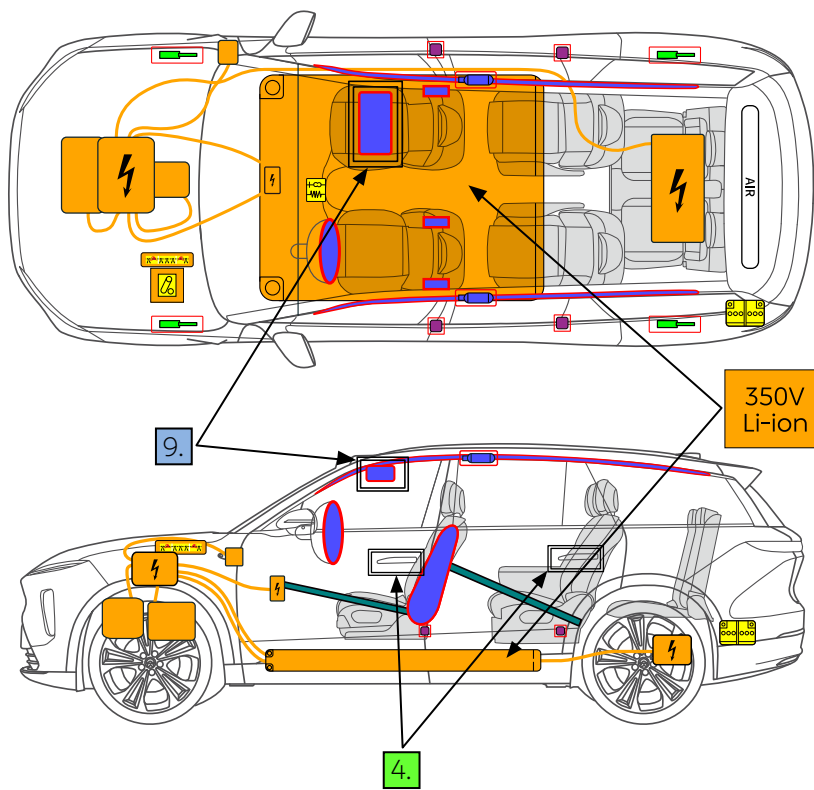



För ytterligare detaljer, se "Guide för nödsituationer".

Airbag i taket

10. Förklaring av piktogram som används

	Varning för högspänning		Lättantändlig
	Försiktighet		Farligt för mänsklig hälsa
	Luftkonditioneringskomponent		Akut toxicitet
	Elfordon		Frätande ämnen
	Huv		Gaser under tryck
	Baklucka		Explosivt ämne
	Använd termisk infraröd kamera		Använd vatten för att släcka branden



 Airbag	 Stored gas inflator	 Seat belt pretensioner	 SRS control unit
 Battery low voltage	 Gas strut /Preloaded spring	 High strength zone	 Zone requiring special attention
 Air tank	 Low voltage device that disconnects high voltage	 Cable cut	 High voltage battery pack
 High voltage power cable /component			



1. Identification / recognition



Silent movement or instant restart capability exists until vehicle is fully shut down.



Model name



Brand name

2. Immobilisation / stabilisation / lifting

A. IMMOBILIZE THE VEHICLE:

1. Shift the vehicle to P gear;
2. Turn on the hazard warning lamp on the central console.



B. LIFTING POINTS:

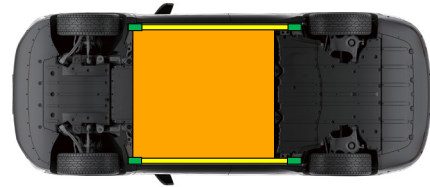

- Appropriate lifting points
- Appropriate points vehicle on side
- High voltage battery

3. Disable direct hazards / safety regulations



Be aware that not every high voltage component is labelled.

Always wear the appropriate PPE (Rubber insulated gloves / insulated rubber shoes / tools with insulating protective cover / goggles). Do not attempt to open the high voltage battery.

MAIN DISABLING METHOD

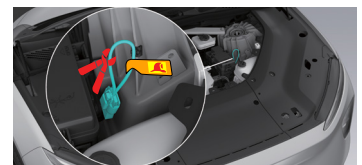
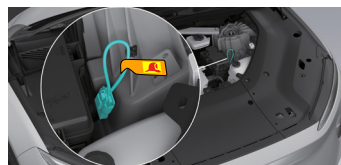

ALTERNATIVE METHOD

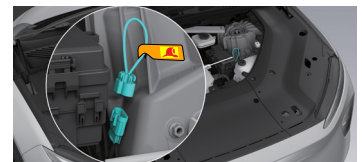
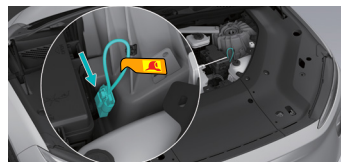

ACCESS TO 12V BATTERY

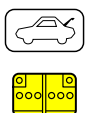



4. Access to the occupants



Driver seat adjustment (electric)

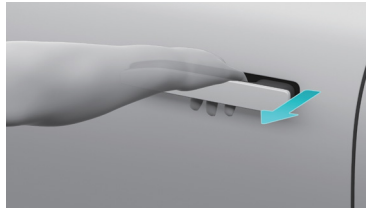

Exterior door handle

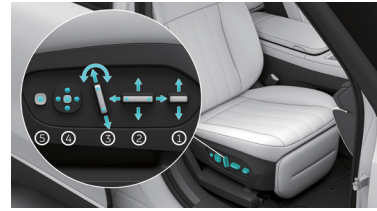

Passenger seat adjustment (electric)



Emergency interior door handle



Steering column adjustment



Door latch

Glass types:



5. Stored energy / liquids / gases / solids

		12 V
		350 V
		1000 g

6. In case of fire

USE LARGE AMOUNTS OF WATER

BATTERY RE-IGNITION!

DO NOT SUBMERGE VEHICLE TO EXTINGUISH BATTERY



7. In case of submersion

Tilt the vehicle to one side to allow water to drain out of the vehicle and the high voltage battery.

Wear appropriate PPE. Remove the vehicle from the water and continue with normal high voltage disconnection (see chapter 3). Vehicles submerged in salt water should be handled with a greater potential risk of a high voltage battery fire.

8. Towing / transportation / storage

STORE AT SAFE DISTANCE FROM OTHER VEHICLES!

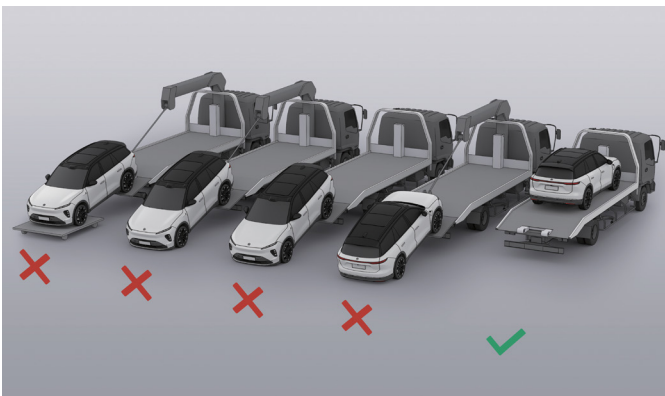

Towing/transportation method



BATTERY RE-IGNITION!

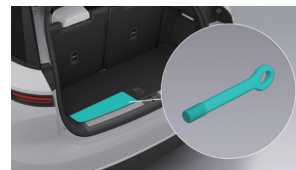

Hook storage



Hook location

9. Important additional information

Manufacturer information NIO

For further details, please refer to "Emergency Response Guide".

Airbag in the roof

10. Explanation of pictograms used

	Warning high voltage		Flammable
	Caution		Hazardous to the human health
	Air-conditioning component		Acute toxicity
	Electric vehicle		Corrosives
	Bonnet		Gases under pressure
	Boot		Explosive
	Use thermal Infrared camera		Use water to extinguish the fire