

Airbag	Gaspatroon	Gordelvoorspanner	SRS-regeleenheid
Lage accuspanning	Gasveer /voorgespannen veer	Hoge-sterktezone	Zone vereist speciale aandacht
Luchtank	Laagspanningsapparaat dat hoogspanning loskoppelt	Kabel doorgesneden	Accupakket (hoogspanning)
Voedingskabel /component (hoogspanning)			

## 1. Identificatie / herkenning



Het voertuig kan stil bewegen of opnieuw starten totdat het volledig is uitgeschakeld.



Modelnaam



Merknaam

## 2. Uitschakeling / stabilisatie / hijsen

### A. SCHAKEL HET VOERTUIG UIT:

1. Zet het voertuig in versnelling P.
2. Zet de alarmlichten aan via de knop op het dashboard.



### B. HIJSPUNTEN:

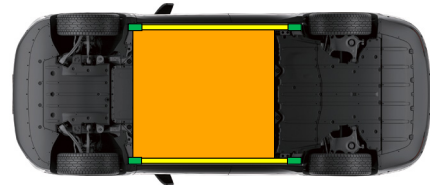

- Geschikte hijspunten
- Geschikte hijspunten gekanteld voertuig
- Hoogspanningsaccu

## 3. Directe gevaren uitschakelen / veiligheidsvoorschriften



Let op dat niet elke hoogspanningscomponent is gelabeld.  
 Draag altijd geschikte PBM (met rubber geïsoleerde handschoenen/met rubber geïsoleerde schoenen/gereedschap met isolerende beschermkap/veiligheidsbril). Probeer de hoogspanningsaccu niet te openen.

### HOOFDUITSCHAKELMETHODE

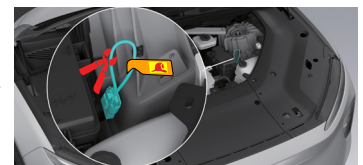
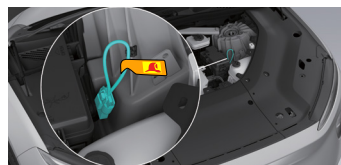

### ALTERNATIEVE METHODE

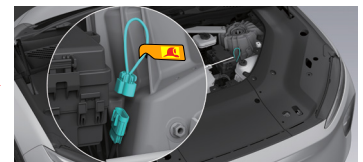
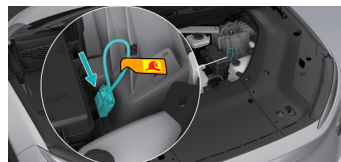
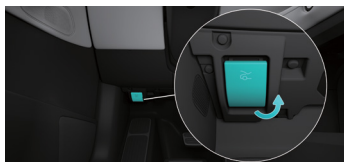

### TOEGANG TOT 12V-ACCU

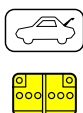



## 4. Toegang tot inzittenden



Verstelling bestuurdersstoel (elektrisch)

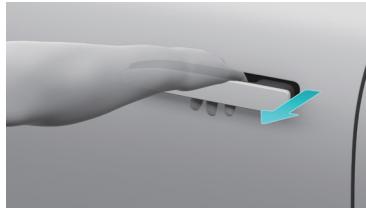

Externe deurgreep



Verstelling passagiersstoel (elektrisch)



Interne deurgreep voor noodgevallen



Stuurkolomverstelling



Deurgrendel

**Glastypes:**

## 5. Opgeslagen energie / vloeistoffen / gassen / vaste stoffen

		12 V
		350 V
		1000 g

## 6. In geval van brand

**GEBRUIK GROTE HOEVEELHEDEN WATER**

**DE ACCU KAN OPNIEUW ONTBRANDEN!**

**ZET HET VOERTUIG NIET ONDER WATER OM EEN ACCUBRAND TE BLUSSEN**

## 7. In geval van tewaterraking

Kantel het voertuig naar één kant, zodat het water uit het voertuig en de hoogspanningsbatterij kan weglopen.

Draag geschikte PBM. Haal het voertuig uit het water en ga verder met de normale ontkoppeling van de hoogspanning (zie hoofdstuk 3). Voertuigen die in zout water zijn beland, hebben een hoger potentieel risico op brand van de hoogspanningsaccu.

## 8. Slepen / transport / opslag

### SLA OP VEILIGE AFSTAND VAN ANDERE VOERTUIGEN OP!

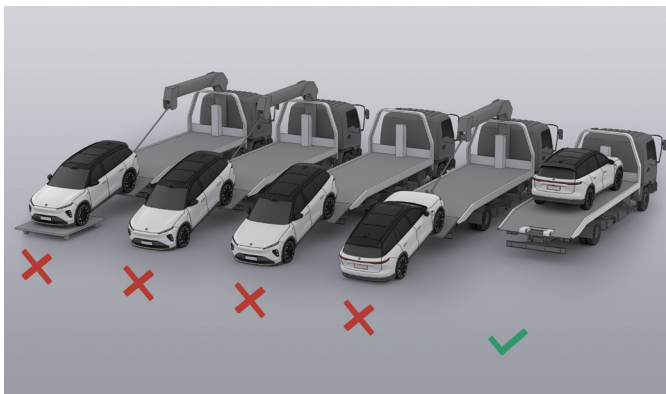

Slepen-/transportmethode



### DE ACCU KAN OPNIEUW ONTBRANDEN!



Haakopslag



Haaklocatie

## 9. Belangrijke aanvullende informatie

Informatie van de fabrikant NIO

Zie "Handleiding voor noodgevallen" voor meer informatie.

Airbag in het dak

## 10. Uitleg van gebruikte pictogrammen

	Hoogspanningswaarschuwing		Ontvlambaar
	Voorzichtig		Schadelijk voor de gezondheid
	Onderdeel airconditioning		Zeer giftig
	Elektrisch voertuig		Bijtend
	Motorkap		Gas onder druk
	Kofferbak		Explosief
	Gebruik een infrarood-warmtecamera		Gebruik water om de brand te blussen

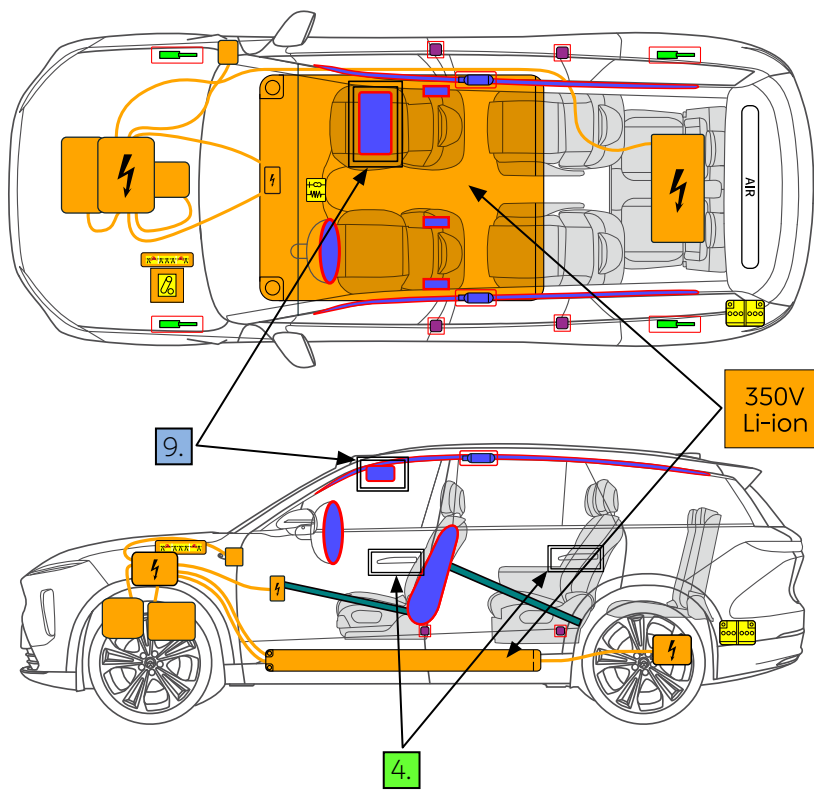

Airbag	Stored gas inflator	Seat belt pretensioner	SRS control unit
Battery low voltage	Gas strut /Preloaded spring	High strength zone	Zone requiring special attention
Air tank	Low voltage device that disconnects high voltage	Cable cut	High voltage battery pack
High voltage power cable /component			

## 1. Identification / recognition



Silent movement or instant restart capability exists until vehicle is fully shut down.



Model name



Brand name

## 2. Immobilisation / stabilisation / lifting

### A. IMMOBILIZE THE VEHICLE:

1. Shift the vehicle to P gear;
2. Turn on the hazard warning lamp on the central console.



### B. LIFTING POINTS:

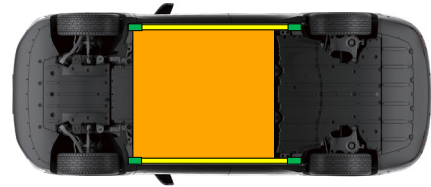

- Appropriate lifting points
- Appropriate points vehicle on side
- High voltage battery

## 3. Disable direct hazards / safety regulations



Be aware that not every high voltage component is labelled.

Always wear the appropriate PPE (Rubber insulated gloves / insulated rubber shoes / tools with insulating protective cover / goggles). Do not attempt to open the high voltage battery.

### MAIN DISABLING METHOD

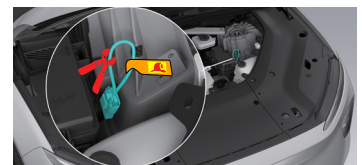
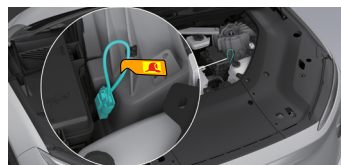

### ALTERNATIVE METHOD

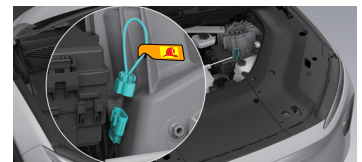
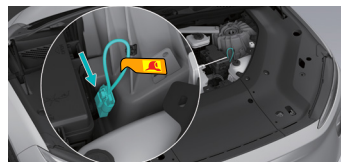

### ACCESS TO 12V BATTERY

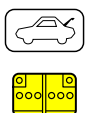



**4. Access to the occupants**



Driver seat adjustment (electric)

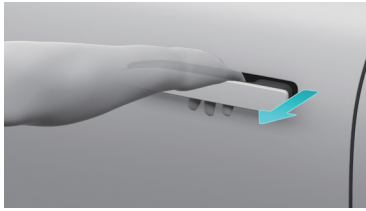

Exterior door handle



Passenger seat adjustment (electric)



Emergency interior door handle



Steering column adjustment



Door latch

**Glass types:**



**5. Stored energy / liquids / gases / solids**

		12 V
		350 V
		1000 g

**6. In case of fire**

**USE LARGE AMOUNTS OF WATER**



**BATTERY RE-IGNITION!**

**DO NOT SUBMERGE VEHICLE TO EXTINGUISH BATTERY**

## 7. In case of submersion

Tilt the vehicle to one side to allow water to drain out of the vehicle and the high voltage battery.

Wear appropriate PPE. Remove the vehicle from the water and continue with normal high voltage disconnection (see chapter 3). Vehicles submerged in salt water should be handled with a greater potential risk of a high voltage battery fire.

## 8. Towing / transportation / storage

**STORE AT SAFE DISTANCE FROM OTHER VEHICLES!**

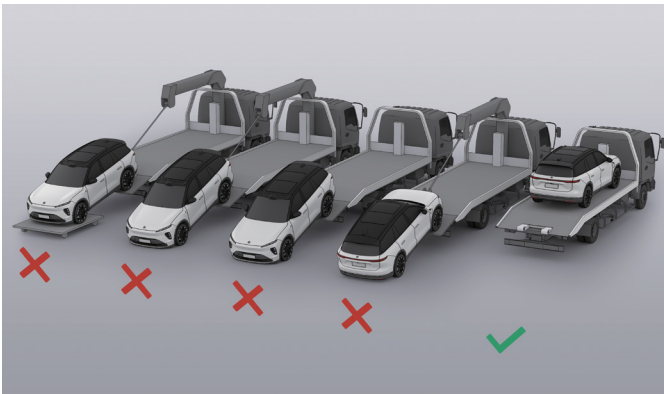

Towing/transportation method



**BATTERY RE-IGNITION!**

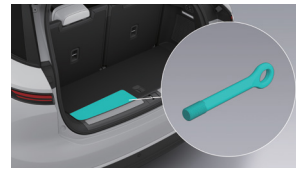

Hook storage



Hook location

## 9. Important additional information

Manufacturer information      NIO

For further details, please refer to "Emergency Response Guide".

Airbag in the roof

## 10. Explanation of pictograms used

	Warning high voltage		Flammable
	Caution		Hazardous to the human health
	Air-conditioning component		Acute toxicity
	Electric vehicle		Corrosives
	Bonnet		Gases under pressure
	Boot		Explosive
	Use thermal Infrared camera		Use water to extinguish the fire