





 Kollisjonspute	 Lagret gasspumpe	 Forspenning av setebelster	 SRS kontrollenhet
 Lavspenbatteri	 Gasstødemper /Forhåndsbelastet fjær	 Sone med høy styrke	 Sone man må være spesielt oppmerksom på
 Lufttank	 Lavspenheten som kobler ut høyspenning	 Kabelkuttet	 Høyspennings batteripakke
 Høyspennings strømledning /-komponent			



1. Identifisering / gjenkjenning



Lydløs bevegelse eller øyeblikkelig omstartfunksjon er tilgjengelig til bilen er helt slått av.



Modellnavn



Merkenavn

2. Immobilisering / stabilisering / løfting

A. IMMOBILISERE BILEN:

1. Sett bilen gir til P;
2. Slå på varselblikkerne på midtkonsollen.



B. LØFTEPUNKTER:

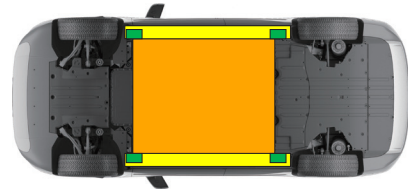

- Egnede løftepunkter
- Egnede punkter på siden av bilen
- Høyspentbatteri

3. Deaktivere direkte fare / sikkerhetsforskrifter



Vær oppmerksom på at ikke alle høyspente komponenter er merket. Bruk alltid passende personlig verneutstyr (gummiisolerte hansker / isolerte gummisko / verktøy med isolerende beskyttelsesdeksel / vernebriller). Ikke prøv å åpne høyspentbatteriet.

DEN VIKTIGSTE DEAKTIVERINGSMETODEN

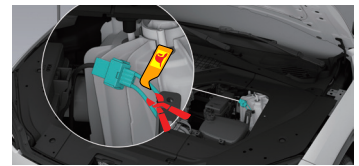
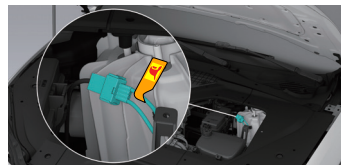
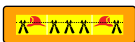

ALTERNATIV METODE

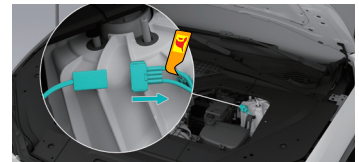
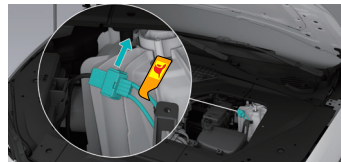

TILGANG TIL 12V-BATTERIET

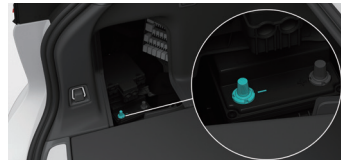
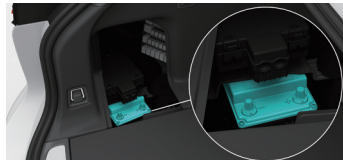



4. Tilgang for passasjerer og fører



Justering av førerasetet (elektrisk)

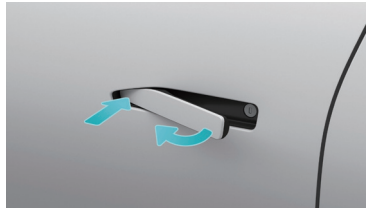

Utvendig dørhåndtak



Justering av passasjerasetet (elektrisk)

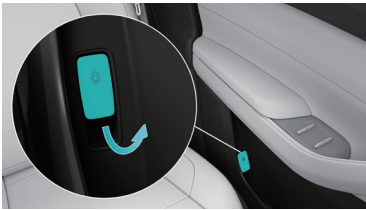

Innvendig nøddørhåndtak



Justering av rattstammen



Dørhåndtak

Glasstyper:

Laminert glass



Herdet glass

5. Lagret energi / væsker / gasser / faste stoffer

		12V
		350V
		1000g

6. I tilfelle brann



BRUK STORE MENGDER VANN



BATTERIANTENNELSE!



IKKE SENK BILEN NED I VANN FOR Å SLUKKE BATTERIET



7. I tilfelle nedsenkning i vann

Velt bilen over på den ene siden for å la vannet renne ut av bilen og høyspenningsbatteriet.

Bruk egnet personlig verneutstyr. Fjern bilen fra vannet, og fortsett med normal frakoblet høyspenning (se kapittel 3). Biler som er nedsenket i saltvann må håndteres med større potensiell risiko for brann i høyspenningsbatteriet.

8. Tauing / transportering / lagring

LAGRES I EN SIKKER AVSTAND FRA ANDRE KJØRETØY!

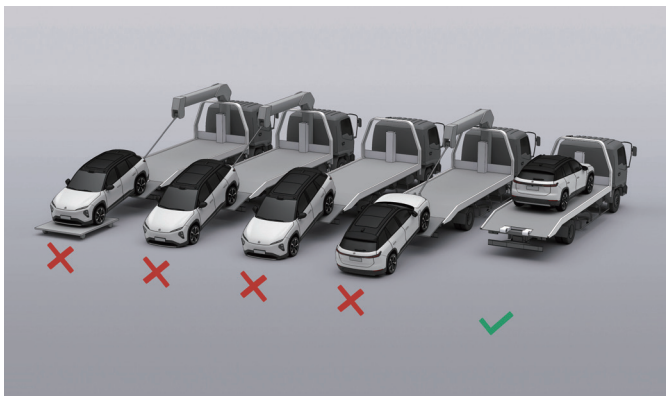

Tau-/transportmetode



BATTERIANTENNELSE!

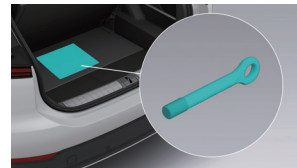

Oppbevaring av kroken



Plassering av kroken

9. Viktig tilleggsmasjjon

Informasjon om produsenten NIO

For mer informasjon, se «Nødhjelpsguide».

Airbag i taket

10. Forklaring av piktogrammene som er brukt

	Advarsel, høy spenning		Brannfarlig
	Forsiktig		Farlig for den menneskelige helse
	Klima-anleggskomponent		Akutt forgiftning
	Elektrisk kjøretøy		Etsende
	Panser		Gasser under trykk
	Bagasjerom		Eksplodivt
	Bruk termisk infrarødt kamera		Bruk vann til å slukke brannen

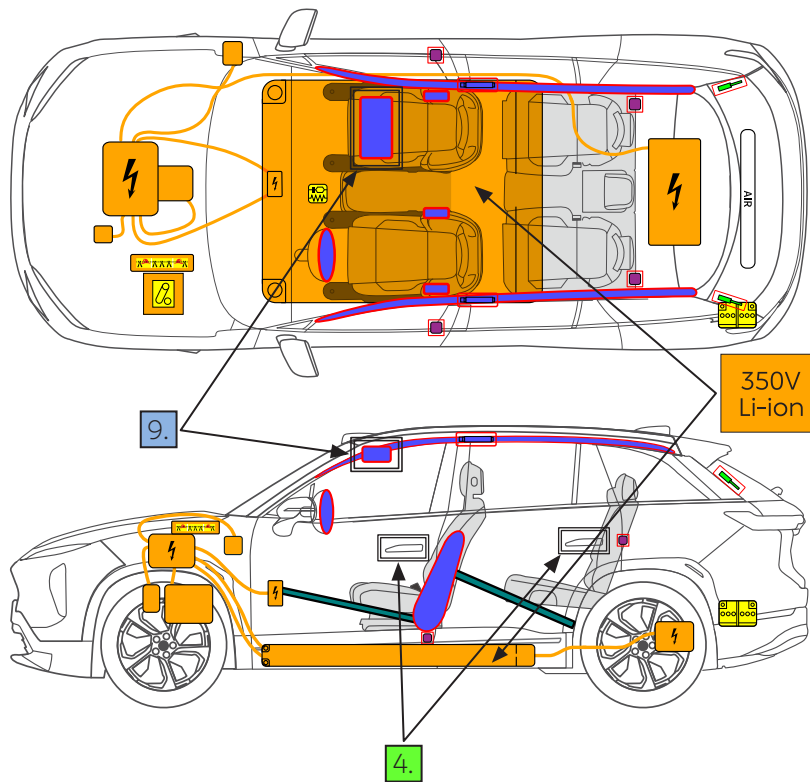

Airbag	Stored gas inflator	Seat belt pretensioner	SRS control unit
Battery low voltage	Gas strut /Preloaded spring	High strength zone	Zone requiring special attention
Air tank	Low voltage device that disconnects high voltage	Cable cut	High voltage battery pack
High voltage power cable /component			

1. Identification / recognition



Silent movement or instant restart capability exists until vehicle is fully shut down.



Model name



Brand name

2. Immobilisation / stabilisation / lifting

A. IMMOBILIZE THE VEHICLE:

1. Shift the vehicle to P gear;
2. Turn on the hazard warning lamp on the central console.



B. LIFTING POINTS:

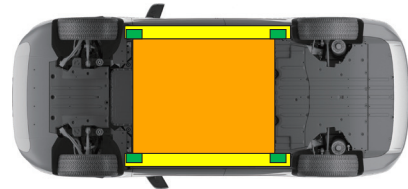

- Appropriate lifting points
- Appropriate points vehicle on side
- High voltage battery

3. Disable direct hazards / safety regulations



Be aware that not every high voltage component is labelled. Always wear the appropriate PPE (Rubber insulated gloves / insulated rubber shoes / tools with insulating protective cover / goggles). Do not attempt to open the high voltage battery.

MAIN DISABLING METHOD

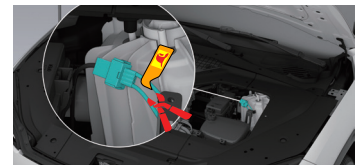
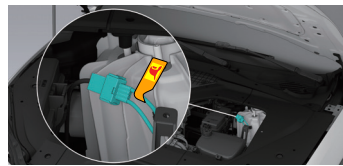
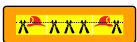

ALTERNATIVE METHOD

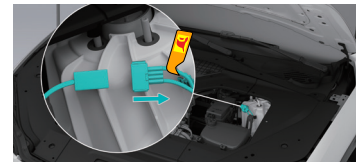
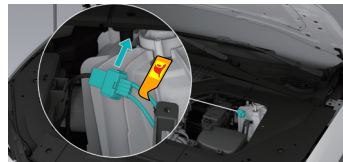

ACCESS TO 12V BATTERY

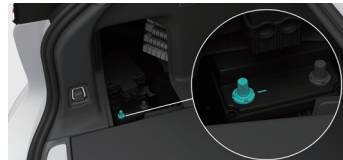
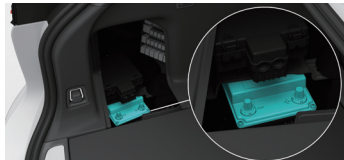



4. Access to the occupants



Driver seat adjustment (electric)

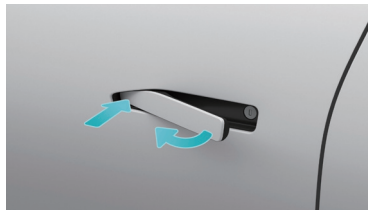

Exterior door handle



Passenger seat adjustment (electric)



Emergency interior door handle



Steering column adjustment



Door latch

Glass types:

Laminated glass



Tempered glass

5. Stored energy / liquids / gases / solids

		12V
		350V
		1000g

6. In case of fire

USE LARGE AMOUNTS OF WATER



BATTERY RE-IGNITION!

DO NOT SUBMERGE VEHICLE TO EXTINGUISH BATTERY



7. In case of submersion

Tilt the vehicle to one side to allow water to drain out of the vehicle and the high voltage battery.

Wear appropriate PPE. Remove the vehicle from the water and continue with normal high voltage disconnection (see chapter 3). Vehicles submerged in salt water should be handled with a greater potential risk of a high voltage battery fire.

8. Towing / transportation / storage

STORE AT SAFE DISTANCE FROM OTHER VEHICLES!

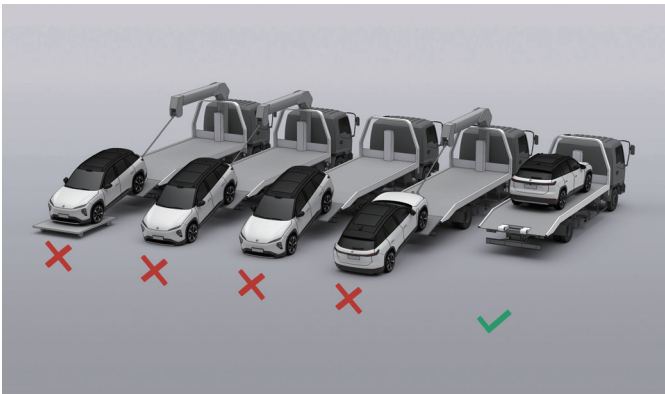

Towing/transportation method



BATTERY RE-IGNITION!

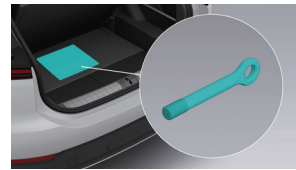

Hook storage



Hook location

9. Important additional information

Manufacturer information NIO

For further details, please refer to "Emergency Response Guide".

Airbag in the roof

10. Explanation of pictograms used

	Warning high voltage		Flammable
	Caution		Hazardous to the human health
	Air-conditioning component		Acute toxicity
	Electric vehicle		Corrosives
	Bonnet		Gases under pressure
	Boot		Explosive
	Use thermal Infrared camera		Use water to extinguish the fire